

SCISSOR LIFTS - BATTERY

12 ME

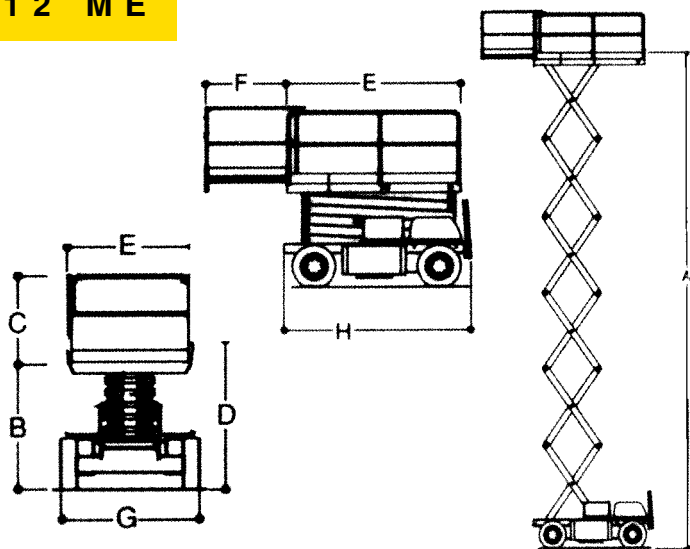

Working Height	12.10m
A Platform Height - Elevated	10.60m
B Platform Height - Lowered	1.49m
C Railing Height	1.12m
D Overall Height (rails folded down)	1.85m
E Platform Dimensions	1.55m x 2.69m
F Platform Extension	1.23m
G Overall Width	1.80m
H Overall Length	2.77m
Safe Working Load	454kg
Capacity on Deck Extension	227kg
Roll Out Deck	1.23m
Motive Power	Battery
Gross Weight (Approx)	3630kg