

SCISSOR LIFTS - BATTERY

1230 ES MAST LIFT

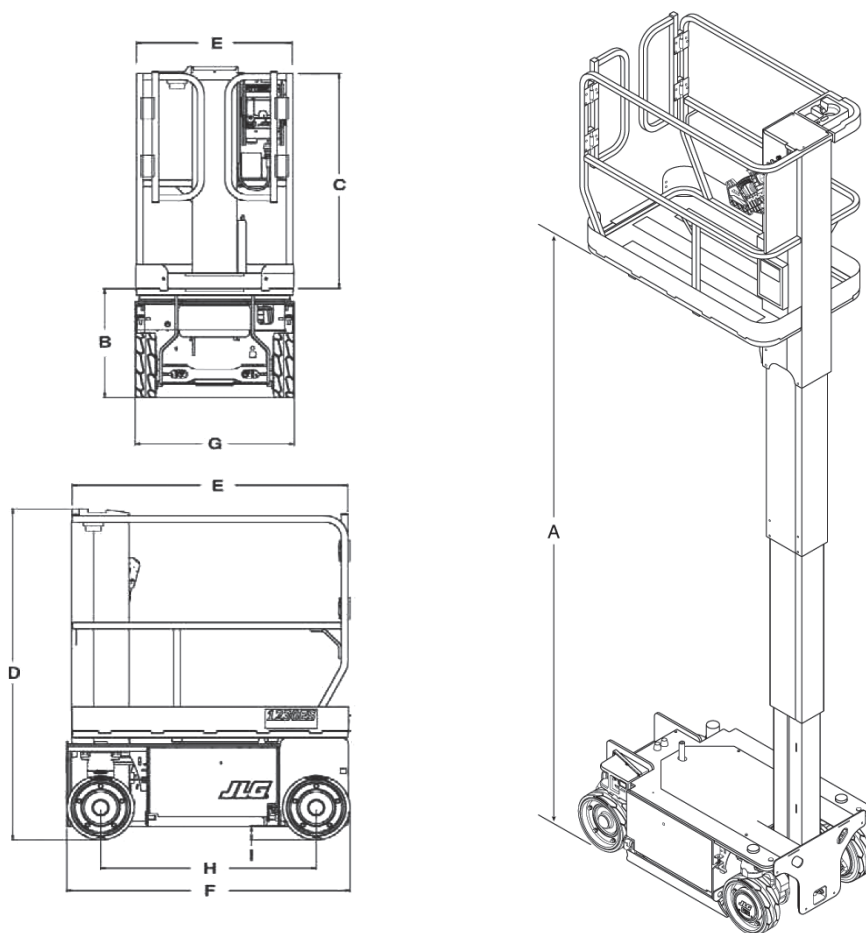

	Working Height	5.66m
A	Platform Height - Elevated	3.66m
B	Platform Height - Lowered	0.56m
C	Platform Railing Height	1.10m
D	Overall Height	1.66m
E	Platform Size	0.68 x 1.25m
F	Overall Length	1.36m
G	Overall Width	0.76m
	Platform Capacity	2.30kg
	Non-Marking Tyres	Yes
	Gross Vehicle Weight (Approx)	790kg